

EK90**THERMO-COOKERS "ECO"**

mm 900x600xh860

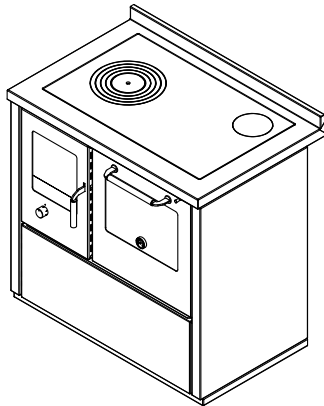

Colours:

White, Blue, Green, Grey, Black, Red, Ivory, Rust, Stainless steel

STANDARD EQUIPMENT

- safety heat exhaust outfitted
- right or left top flue outlet \varnothing 130 mm
- cast-iron hotplate mm 740x450 with cooking rings set
- black doors
- oven mm. 360x440xh260 with oven light and thermometer
- stainless steel frame of mm 40 (total h860 mm) A2-B4
- s.steel handles D3
- stainless steel base h. 30 mm

ON DEMAND

- rear flue outlet, right or left \varnothing 130 mm
- s.steel doors
- glass-ceramic hotplate (rear flue only)

OPTIONALS

- front handrail s.steel or brass, 2 or 3 sides
- heavy-duty radiant hotplate
- stainless steel hotplate cover

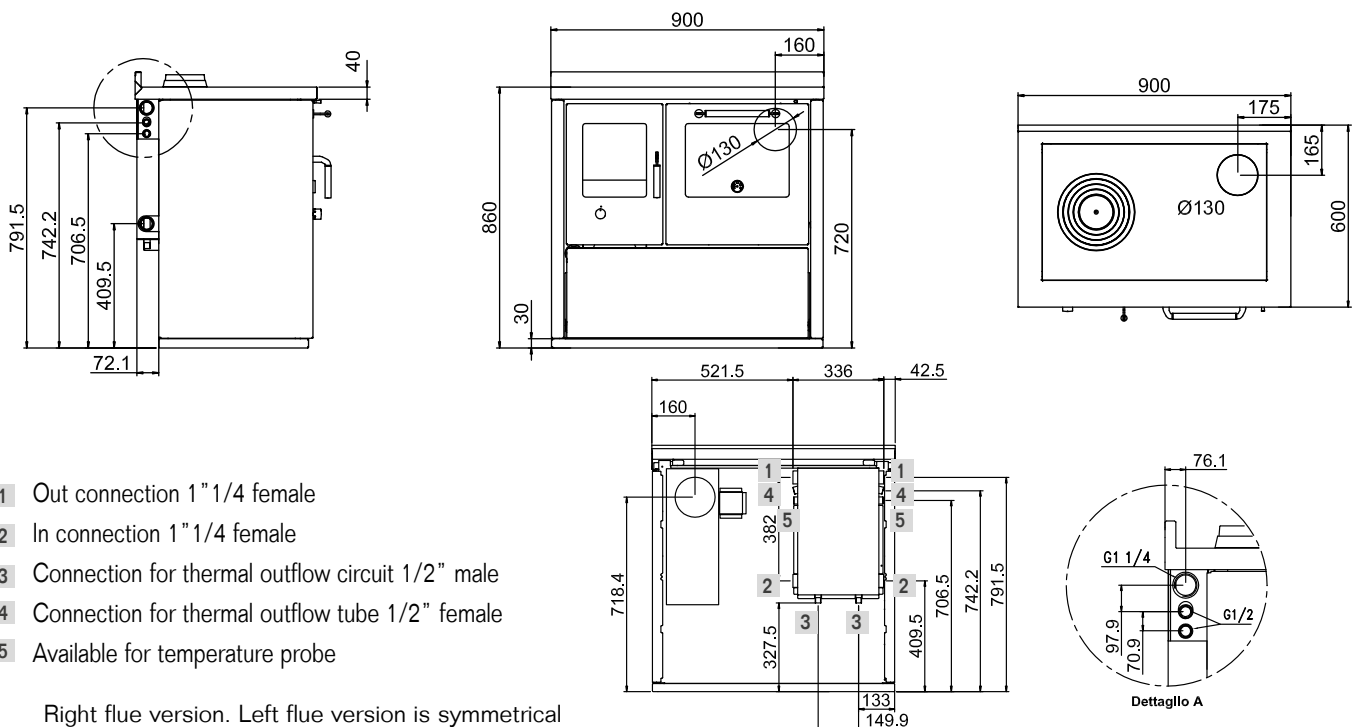
**DATA SHEET**

Energy Efficiency Class: A+	Efficiency: 85.4 %
Nominal heat output (max): 12.7 (20) kW	Nominal water heat output (max): 4.6 (14) kW
Mean content of CO to 13% O ₂ : 0.09 %	Average DUST content to 13% O ₂ : 21.1 mg/Nm ³
Maximum operating pressure: 2.0 bar	Boiler capacity: 20 Lt
Hearth dimensions (LxPxH): 22x41x45 cm	Fill opening (LxH): 22x25 cm
Mean flue gas temperature: 228 °C	Flue gas mass flow: 9.9 g/s
Flue depression: mbar 0.12	Net weight/packaging included: kg 195/210